



SuperOne Ci

In-Wall Loudspeaker

OWNER'S MANUAL

Now Hear This
6400 Goodyear Road
Benicia, CA 94510
800-NHT-9993

Thank you for your purchase of the NHT SuperOne Ci in-wall loudspeaker. Please take a few minutes to read through this Owner's Manual prior to installing your new speakers. The information provided will help you to obtain maximum performance from your audio system. If you have questions or need assistance at any time during the installation or operation of your new speakers, please call your NHT Dealer or our Toll-Free Customer Hotline at:

1-800-NHT-9993

SuperOne Ci Specifications

- **System Type:** 2-way in-wall design
- **Driver Complement:** 6.5" long-throw woofer, 1" fluid-cooled soft dome tweeter
- **Crossover:** 2.6KHz, 6dB/octave high-pass and 12dB/octave low-pass
- **Response:** 50Hz - 20KHz, +/- 3dB
- **Sensitivity:** 86.5db (2.83V at 1M)
- **Impedance:** 8 ohms nominal
- **Recommended Amplifier Power:** 10W/ch minimum, 100W/ch maximum
- **Inputs:** Professional grade spring posts
- **Weight:** 3.8 lbs. each
- **Dimensions:** Cutout 12-1/8"H x 8"W; Bezel 13-1/8"H x 9"W; Depth behind wall 2-3/4"
- **Finish:** Matte white (paintable)

Specifications are subject to change without notice, in accordance with our policy of continuously upgrading the performance of our products.

■ Design

NHT loudspeakers are designed to deliver refined, musical sound from attractive and affordable packages. Our efforts are guided by the study of human hearing and are optimized for real-world use. Every NHT speaker undergoes rigorous testing and quality control at the factory to ensure you years of listening pleasure.

The SuperOne Ci is designed to deliver the sonic performance and value of NHT's acclaimed SuperOne freestanding loudspeaker, while offering the invisibility of in-wall installation. Its custom-designed drive units are mounted in a rigid baffle/bezel assembly designed to minimize the audible effects of unwanted vibrations and resonance. The mounting assembly is designed to be intuitive and flexible, making it ideal for new or existing construction. With high performance sonics and a paintable face, the SuperOne Ci is the perfect solution for architectural audio and home theater installations.

Caution: *The SuperOne Ci should be installed by an experienced and licensed custom installation professional. Be sure that the installer possesses sufficient skill, the proper tools, knowledge of local fire and building codes, and a familiarity with the structure of the building (especially wall and/or ceiling materials, layouts, electrical and plumbing lines, etc.).*

■ Placement

The SuperOne Ci is designed for in-wall installation between standard 2" x 4" wood studs. Installation in outdoor locations or in moisture-prone interior environments such as indoor swimming pools or saunas is not recommended.

Spend some time considering speaker placement prior to installing the SuperOne Ci. Once the speakers are installed, they are permanent, so their location should be selected carefully. Mount the speakers in a location where they face the listening area without obstruction from furniture, and preferably at least three feet from side walls. The speakers should be mounted on a flat surface to ensure a good seal between the baffle and the mounting surface. For optimal imaging, position the speakers so that the distance between the listening position and the wall is 1.5 times the distance

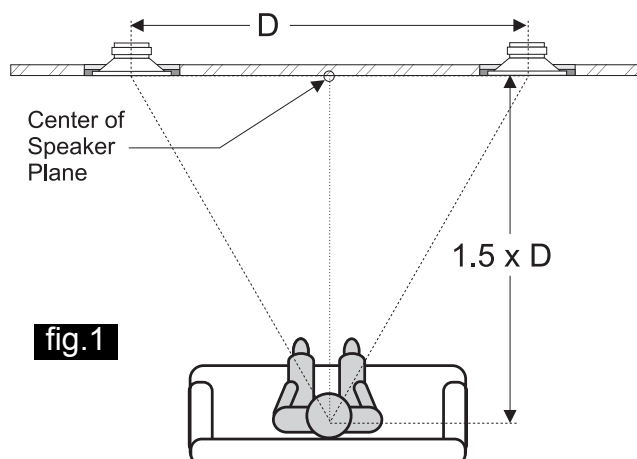

between the two speakers (fig.1). To get an idea how they will look in the room, try taping the supplied cutout templates to the wall. Keep in mind that room furnishings play an important role in absorbing and reflecting soundwaves. Midrange and high frequencies in particular will be absorbed by soft furnishings such as sofas, carpets and curtains. A large number of these soft furnishings will dull the sound, while a “live” room with few furnishings will brighten the sound. As the SuperOne Ci is not magnetically shielded, do not install it in a location where it will be within 18” of a television. Unshielded magnets placed in close proximity to a television screen can cause picture discoloration and eventually damage the picture tube. When installing three SuperOne Ci’s for front channels in a home theater system, you can position the L & R speakers farther apart to create a wider soundstage. When installing a SuperOne Ci as a center channel speaker, it should be installed at least 18” directly above the location where the television will be.

Packing List (each speaker):

“SuperOne Ci” pack includes:

- (1) Baffle with drivers
- (6) 4 x 16mm panhead screws

“Bezel and Grille” pack includes:

- (1) Bezel
- (1) Metal grille
- (6) 4 x 16mm flathead screws
- (6) Small foam rubber absorbers
- (6) Large foam rubber absorbers

“Mounting Bracket” pack includes:

- (1) Mounting bracket
- (2) Mounting wings
- (4) 5 x 50mm flathead screws
- (1) Cutout template - paint shield

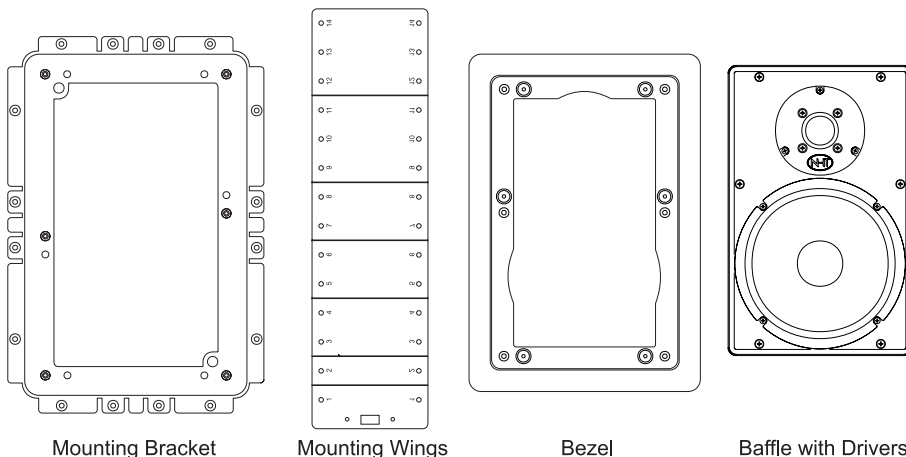

Tools Needed:

- #2 Philips screwdriver
- Pencil
- Tape measure
- Utility knife or keyhole saw
- Level
- Wire strippers
- Safety goggles
- Protective gloves

Tech Tips: Pre-Wiring for New Construction

1. For best results, avoid running speaker cable near electrical wire, as it may induce a 60Hz hum in the audio signal. It's a good idea to run the speaker cable after the electrical wiring has already been completed, so that you can route the speaker cable at least three feet away from the electrical wiring. If speaker cable and electrical wiring must run parallel, install the cable within a metal conduit. Note that low-voltage wiring (doorbell, intercom, telephone, security, etc.) are unlikely to induce hum and can typically be run parallel to speaker cable with no detrimental effects.

2. When drilling holes through wall studs or ceiling joists, use a drill bit that is at least as wide as the speaker cable that will be routed through them. Always drill through the center of the stud or joist. If the hole must be drilled within one inch of the edge of a wall stud, add a nail plate to the drywall side to protect the cable from possible nails and screws put in the wall later. Line up the holes in the studs or joists as you go, so that pulling the cable through them will be easier.

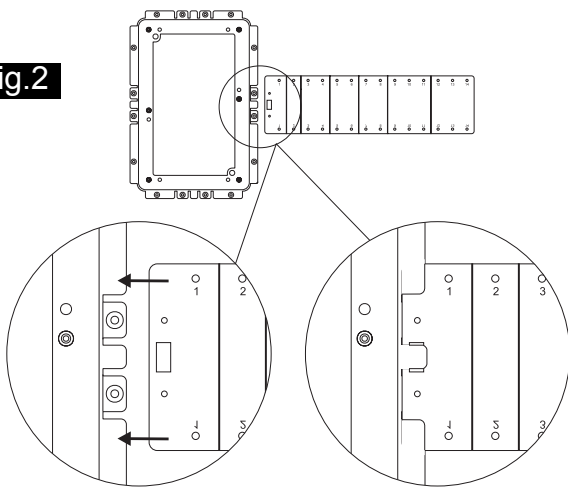
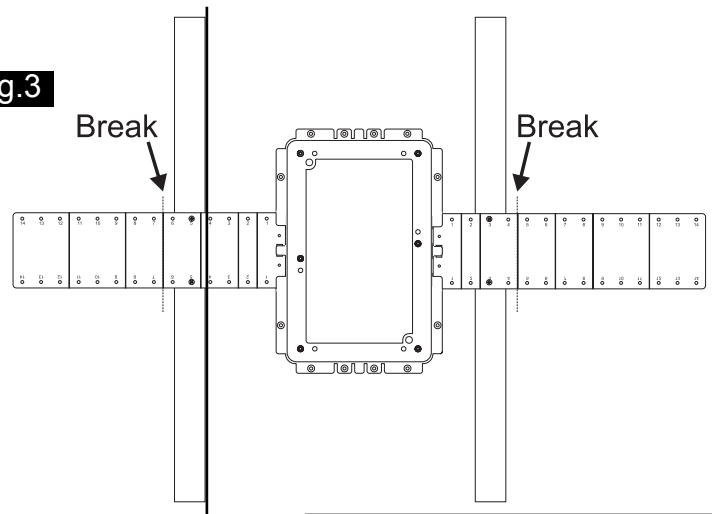
fig.2**fig.3**

■ Installation: New Construction (unfinished walls)

1. Begin by installing the mounting bracket between adjacent studs. The SuperOne Ci performs best in the vertical orientation. Be sure to mount the bracket in the appropriate direction so that the tweeter is at the top. Attach the mounting wings to the bracket by inserting them into the locking plastic tabs in the side of the bracket (fig.2).

2. Select the desired location for the speaker, using a level to ensure that it is precisely positioned. The wings feature progressively elongated sections (1", 1", 2", 2", 2", 3", 3") with screw holes spaced in one-inch increments. Attach the wings to the studs with the 5 x 50mm flathead screws. For maximum stability, use two screws for each wing. Break off the extra portion of the wing by snapping it at one of the pre-molded "break" lines (fig.3).

3. Complete the pre-wiring before the drywall goes up (see *"Tech Tips: Pre-Wiring for New Construction"*). Leave an extra few feet of speaker cable, and secure it to the cable tie on the mounting bracket (fig.4).

4. During the drywall phase, cut a hole 12-1/8" high by 8" wide around the bracket. The bezel outer frame will extrude out about 1 inch beyond the perimeter of the cutout to hide minor imperfections in the cutout.

5. If the SuperOne Ci bezel frame and grille are to be painted in the wall, paint now before installing the baffle (see *"Painting"*).

6. After the drywall is complete, attach the bezel to the bracket with six 4 x 16mm flat-head screws that line up with the six raised bosses on the bracket (fig.5). If the frame is not installed in the proper orientation, all six screw holes will not line up. Tighten screws snugly, making sure not to over-tighten, as this may compromise the fit of the bezel. The use of power screwdrivers is not recommended. The absorptive strips on the back of the bezel's outer frame reduce unwanted vibrations and will compress slightly to allow the frame to rest flush against the wall on all four sides. When installed correctly, the bracket and bezel "sandwich" the drywall.

7. Connect the speaker cable to the spring posts on the SuperOne Ci baffle, making sure to observe correct polarity (see *"Connections"*).

8. Place one of the large foam isolators in each of the six raised bosses on the bezel. Place one of the small foam isolators in each of the 6 holes on the front surface of the baffle. Put the baffle into the bezel so the holes on the baffle line up with the holes in the center of the raised bosses on the bezel (fig. 6). Push one of the 4 x 16mm screws through a hole on the baffle and into the hole on the bezel and tighten it by hand so that the baffle and the bezel stay together. Insert the remaining screws, then tighten all of them snugly, making sure not to overtighten, as this may compromise the fit of the baffle. The use of power screwdrivers is not recommended. Exercise caution not to damage the drivers when inserting the screws.

9. Attach the metal grille by inserting it into the grooves in the baffle.

fig.4**fig.5****fig.6**

fig.7**fig.8**

■ Installation: Existing Construction (retrofitting finished walls)

Warning: Exercise caution when drilling into existing walls. Do not drill through existing wires, pipes, conduits, heating or air conditioning ducts. If you feel resistance while drilling, stop immediately.

1. Using a studfinder or the “knocking” method, locate the wall studs in the wall area where you wish to mount the speaker. The speaker will be mounted between adjacent studs, no closer than two inches from either stud (fig.7).
2. Determine that there are no obstructions behind the desired cutout area. This may be accomplished by drilling a hole in the center of the cutout area and using an “L”-shaped piece of metal (like a coat hanger) to “feel around” behind the wall. If you discover an obstruction, fill the hole with patching compound and try another location.
3. If there are no obstructions found behind the wall, use the supplied cutout template and a pencil to draw a 12-1/8”H x 8”W outline of the area to be cut out. Use a level to ensure that the cutout is precisely positioned. Begin by drilling the four corners with a 1/4” bit (fig.7). Then cut out the wall section with a utility knife or keyhole saw, following the lines traced around the mounting template. If the wall is painted or wallpapered, use the keyhole saw.
4. If the wall is constructed of lath and plaster, outline the penciled marks with masking tape, drill the four corners with a 1/4” drill bit, and use a utility knife to cut through the plaster down to the lath. Use a saber saw with a metal cutting blade or a pair of tin snips to gently cut through the lath, being careful not to vibrate plaster off the wall.
5. Insert the SuperOne Ci mounting bracket diagonally through the cutout in the wall, then pull forward into position. If the cutout was cut correctly according to the cutout template, the bracket should fit snugly into place. The plastic tabs on all sides of the bracket will rest flatly against the back side of the wall (fig.8).
6. While holding the bracket flatly against the rear side of the wall with one hand, attach the bezel to the bracket with six 4 x 16mm flathead screws that line up with the six raised bosses on the bracket (fig.9). If the bezel is not installed in the proper orientation, all six screw holes will not line up. Tighten screws snugly, making sure not to over-tighten, as this may compromise the fit of the bezel. The use of power screwdrivers is not recommended. The absorptive strips on the back of the bezel’s outer frame prevent unwanted vibrations against the drywall, and will compress slightly to allow the frame to rest flush against the wall on all four sides. When installed correctly, the bracket and bezel “sandwich” the drywall.
7. If the SuperOne Ci bezel frame and grille are to be painted in the wall, paint

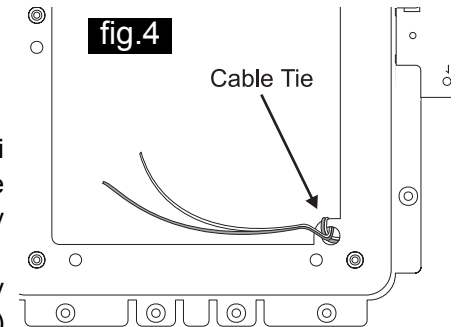
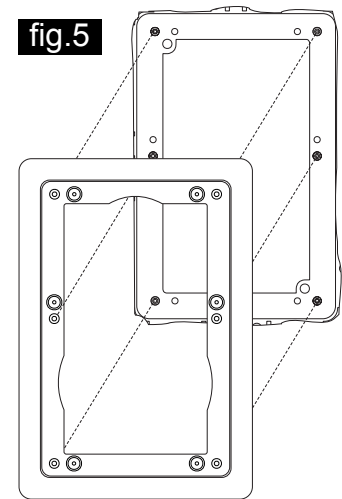
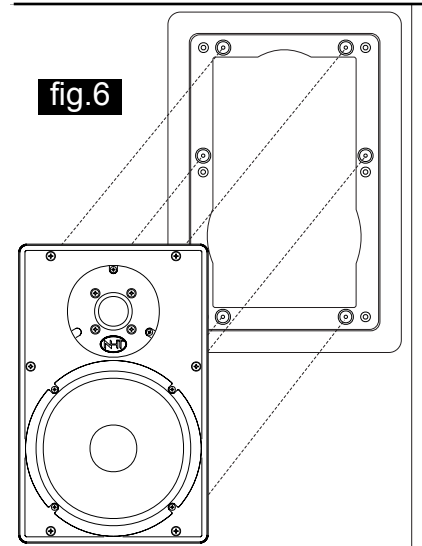
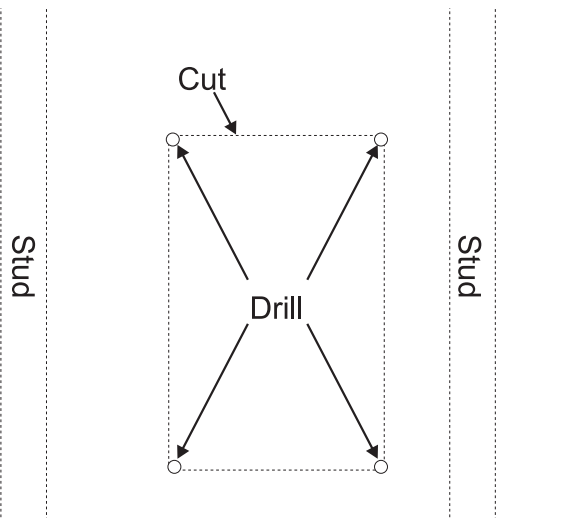
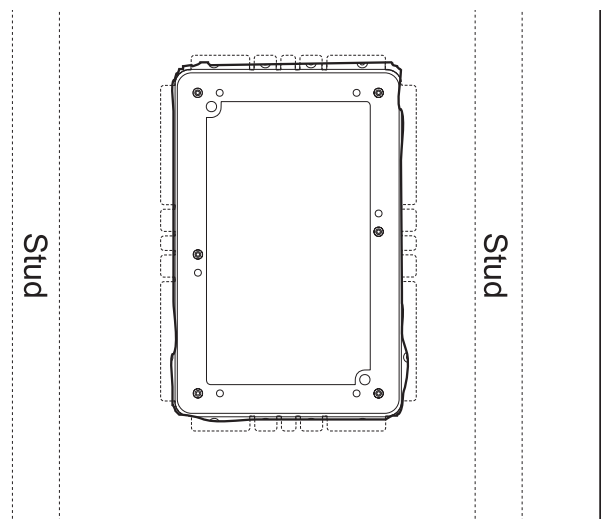
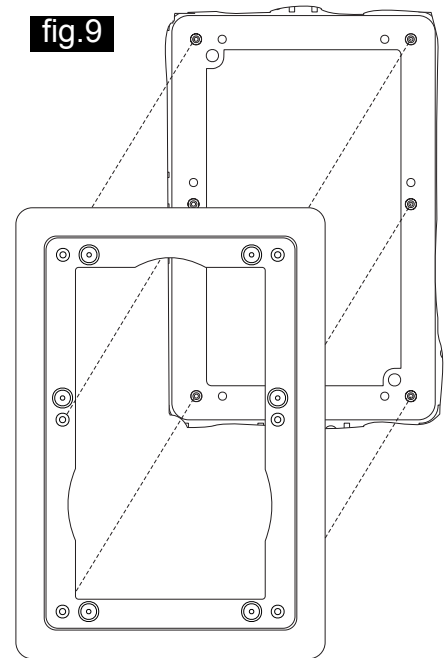
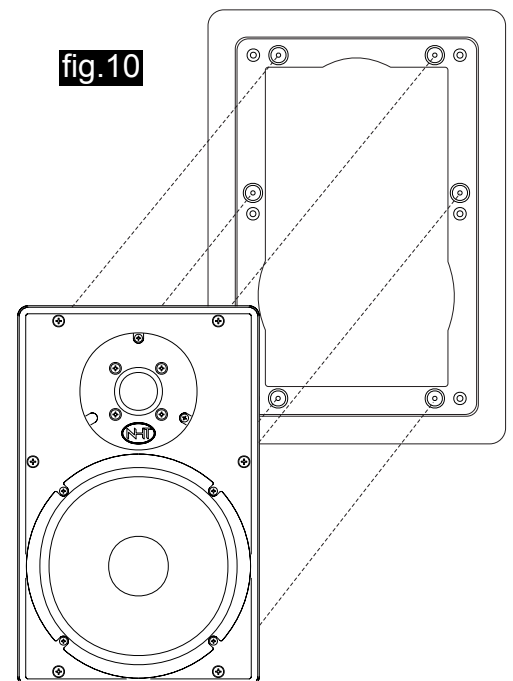
fig.9**fig.10**

Tech Tips: Optimizing Sonic Performance

Bass response is smoothest when the speaker is mounted within a rigid wall that flexes very little. For improved performance, add 2"x4" cross-braces horizontally roughly one foot above and one foot below the speaker location. Use wood glue and extra screws when attaching the drywall to the studs around the speaker. Additionally, once the speaker cutout has been made in the drywall, add a bead of wood glue inside the wall where the drywall meets the studs and cross-braces. If possible, use two layers of drywall for maximum rigidity.

For more controlled bass response, add insulation to the wall cavity around and behind the speaker to provide acoustic damping. Be sure to add the same amount of insulation to speakers in the same room to ensure consistent sound. Use R-12 or R-19 fiberglass insulation, and be sure to wear protective gloves to avoid contact with the fibers. If the insulation is paper- or foil-faced, position the paper or foil side away from the speaker.

now before installing the baffle (see "Painting").

8. Connect the speaker cable to the spring posts on the SuperOne Ci baffle, making sure to observe correct polarity (see "Connections").
9. Place one of the large foam isolators in each of the six raised bosses on the bezel. Place one of the small foam isolators in each of the 6 holes on the front surface of the baffle. Put the baffle into the bezel so the holes on the baffle line up with the holes in the center of the raised bosses on the bezel (fig. 10). Push one of the 4 x 16mm screws through a hole on the baffle and into the hole on the bezel and tighten it by hand so that the baffle and the bezel stay together. Insert the remaining screws, then tighten all of them snugly, making sure not to overtighten, as this may compromise the fit of the baffle. The use of power screwdrivers is not recommended. Exercise caution not to damage the drivers when inserting the screws.
10. Attach the metal grille by inserting it into the grooves in the baffle.

■ Painting

The bezel frame and grille of the SuperOne Ci are finished in a matte white powder-coated finish that may be painted to match the wall. The frame and grille may be painted either before or after the speaker is installed. Keep in mind that the grille contains hundreds of tiny holes that are essential to the sound of the speaker. Take care not to cover these holes with paint.

1. Paint the bezel frame and the grille at the same time using the same paint. Use the supplied paint shield (fig.11) to protect the inside of the bezel from overspray (paint will reduce the effectiveness of the absorptive materials). Fold the corners down and insert the paint shield into the grooves where the grille would attach. Be careful not to punch through the round hole in the middle of the shield.
2. When using spray paint, apply two thin coats, making sure to let the first coat dry completely before applying the second. This will avoid running. When using a compressor and spray gun, apply the paint using its finest setting. Painting with a brush is not recommended, but when necessary be sure to thin the paint so as not to cover the holes in the grille. If paint does cover any of the grille holes, poke them out with a paper clip.
3. Once painting is complete, remove the paint shield from the bezel by carefully punching out the round hole in the middle, and using this hole to pull the shield free. Do not attempt to paint the black baffle surface (which houses the drivers) behind the grille. Its black finish prevents the speaker's black drive units from being visible once the grille is attached.

■ Connections

Before connecting speakers to your system, it is important that you turn off the power to your amplifier / receiver to avoid damage to the equipment. Before installing the SuperOne Ci, map out the wiring paths between the speakers and the amplifier. Make sure that the speaker cable does not rest on sharp or pointed objects.

The SuperOne Ci is compatible with virtually all quality amplifiers. Proper wiring of the speakers is essential to good sound. At a minimum, 16AWG 2-conductor speaker cable is recommended for runs of 10 feet or less, with heavier special purpose speaker cable used for longer runs. For best results, use equal length runs of cable for the left and right

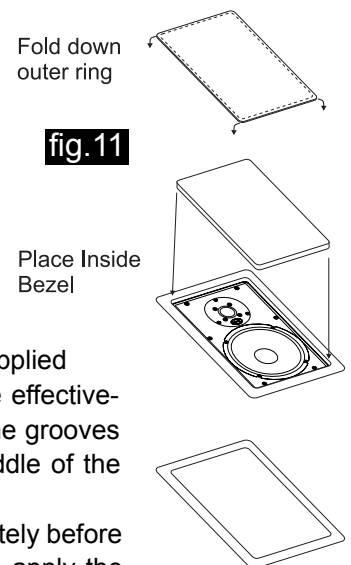

speakers. **When permanently installing cable inside walls, be sure to use cable that is rated for in-wall use and has special jacketing for fire prevention. In the U.S., the U.L. standard is CL-2, CL-3 and CM cable, and in Canada the CSA standard is FT4 cable. The cables should be run in accordance with National Electrical Code and any applicable local building codes.** Prepare the cable by stripping 1/4" to 3/8" of insulation from the ends and twisting the exposed wire strands tightly. The spring-loaded binding posts on the back of the speaker will accept raw wire only.

Be sure to wire both the left and right speakers "in-phase." That is, the Positive (red) terminal on the amplifier output must be connected to the corresponding Positive (red) terminal on the speaker. Likewise with the Negative (black) terminals. All speaker cables have some sort of marking along one or both conductors to help you make the correct connections. Incorrect speaker phase is indicated by weak bass and the lack of a well-defined stereo image.

■ Operation

The SuperOne Ci was designed to handle a wide range of listening levels, but every speaker has limits. It is important to use common sense and listen for signs of possible distress from the speakers. Underpowered amplifiers are most often the cause of speaker damage. For example, a 60-watt amplifier runs out of power when called upon to produce more than 60 watts, and the resulting distortion can damage the speaker. If you tend to listen at high volume levels, more powerful amplifiers are preferable because they are less likely to run out of power.

Noticeable distortion or harsh breakup is an indication that either your amplifier or your speakers are running beyond their capacity, and the volume should be decreased. If you can feel any heat emanating from the woofer or tweeter, reduce the level immediately. Speaker damage most often occurs from sustained high volume levels, not from transient sounds or brief musical peaks. Excessive boosting of bass, treble or equalizer controls can worsen the problem, and is not recommended.

■ Maintenance

The SuperOne Ci's require minimal maintenance under normal use. The grille and frame may be cleaned using a damp cloth or a mild, non-abrasive cleaner. Do not expose the speaker to direct sunlight, high temperatures, or moisture. Do not attempt to clean the actual drivers.

Limited Warranty Valid Only in the U.S.A.

Warranty Period

For the period of 5 years for parts and 5 years for labor from date of original purchase (the warranty period) from an authorized NHT dealer, Now Hear This (NHT) warrants that if our product fails to function properly under normal use due to a manufacturing defect when installed and operated according to the owner's manual instructions enclosed with the unit, it will be repaired or replaced with a unit of comparable value at the option of NHT without charge to you for parts or actual repair work. Parts supplied under this warranty may be new or rebuilt at the option of NHT.

What's Not Covered

This warranty does not cover any product which is used in any trade or business, or in an industrial or commercial application.

This warranty does not cover the cabinet or any appearance item, or any damage caused to the product resulting from: alterations, modifications not authorized in writing by NHT, accident, misuse or abuse, damage due to lightning or power surges, or being subjected to power in excess of the speaker's published power rating.

This warranty does not cover the cost of parts which would otherwise be provided without charge under this warranty, obtained from any source other than an authorized NHT service location. This warranty does not cover defects or damage caused by the use of unauthorized parts or labor or from improper maintenance.

Altered, defaced or removed serial numbers void this warranty.

Your Rights

The liability of NHT will be limited to the purchase price of the product, and NHT will not be liable for incidental or consequential damages. NHT limits its obligations under any implied warranties under state laws to a period not exceeding the warranty period. Some states do not allow limitations on how long an implied warranty lasts, and some states do not allow the exclusion or limitation of incidental or consequential damages. The above limitations or exclusions may not apply to you. This warranty gives you specific legal rights, and you may have other rights which vary from state to state.

To Obtain Service

NHT has appointed a number of authorized service companies throughout the USA should your product ever require service. To receive warranty service, you will need to present your sales receipt showing place and date of original owner's transaction.

To find the name and address of the nearest authorized NHT service location, call or write: **Customer Service Department, Now Hear This, 6400 Goodyear Road, Benicia, CA 94510. 800-NHT-9993.**

Please do not return product to this address. It is not a service location.

Keep this warranty with your sales receipt. Record date and place of purchase for future reference.